



MX7 Flex Power Box Rake®

FOR PRECISION GRADING AND CONTOURING

MX7 Flex Power Box Rakes®

Flex means that you have more control than ever before!

Enjoy the same proven productivity and consistent performance of a Harley Rake now with more capabilities.

- Hydraulically adjustable gauge wheels.
- Control depth of horizontal raking through gauge wheels.
- Professionally contour and grade landscape jobs.
- Laser Ready.

The Harley Power Box Rake is the ultimate landscaping and seedbed preparation tool. Use it for:

- Grading and shaping**
- Digging and plowing material**
- Windrowing debris**
- Drying out muddy job sites**
- Reconditioning hard soil**
- Rejuvenating old turf**
- Seedbed preparation**
- Trench restoration**

Horizontal flexing for grading and contouring is the latest Harley innovation. With 9 degrees of flexing across the width of the rake - you have never had this amount of control from the seat of your cab!

Well built, easy to use and easy to maintain... Harley rakes have been the versatile landscaper's choice for over 25 years!



The Power of Combined Excellence



The only Horizontally Controlled Power Box Rake on the market today!

MX7 Flex Power Box Rake®

FEATURES:

- **Hydraulically adjustable gauge wheels control raking depth.** Set depth with the push of a button. Professionally contour the toughest landscape jobs.
- **Pure carbide proprietary teeth design.** Not just carbide tough for long life, but specifically shaped to ensure the best possible seedbed sub-base fracture pattern and superior moisture retention and release.
- **Adjustable polyurethane barrier** above the roller allows you to quickly react to soil moisture conditions - from opening up muddy sites to finishing with the perfect seedbed.
- **Quick and easily removable endplates** allow windrowing and debris placement - no bolts, just pull the pins.

Why haul around all of those attachments?

Grade, level, rake and remove debris.
Pulverize and prepare seedbed, dethatch or remove old lawns and weeds...all with one tool

The Harley rake is four attachments in one!

Specifications	Flex
Weight (lbs)	1450
A. Length (overall)	70"
B. Width	94"
C. Raking Width	84"
D. Raking Width (full angle)	79"
E. Angle Roll R or L	20°
Min. gpm	15

Specifications and design are subject to change without notice and without liability, therefore, whenever applicable specifications are in accordance with SAE standards.

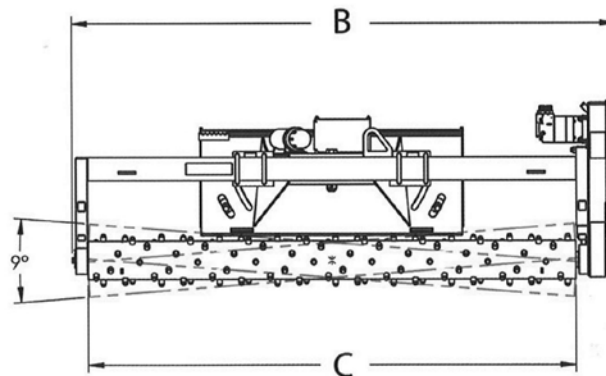
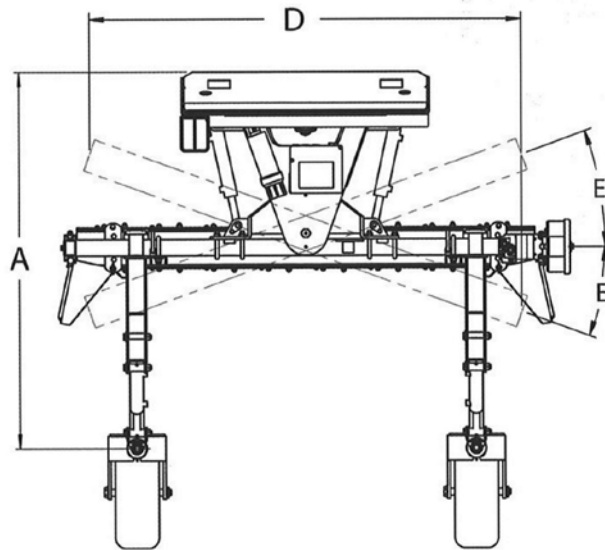

PH: (800) 456-7100

www.paladinbrands.com

PALADIN.
LIGHT CONSTRUCTION

BRADCO

FFC

HARLEY

MCMILLEN

SWEEPSTER

The Power of Combined Excellence