

Swing Hoe

For Skid Steer Loaders.

JUST RELEASED!



PALADIN LIGHT CONSTRUCTION

FEATURES:

- Electric over hydraulic controls to operate both the swing and bucket functions from inside the skid steer loader
- Swing cylinder provides 140° of rotation to allow the placement of spoil outside the tracks of a 72 inch wide skid steer
- Optional fixed thumb available
- Bucket linkage improves bucket breakout force with increased bucket rotation
- Bucket sizes available: 10", 12", 16", 18", and 24"
- Cushioned swing cylinder for smooth operation with equal swing force in both directions for reduced maintenance costs



Swing Hoe

FEATURES:

- Replaceable hardened bushing and grease fittings on all pivot points for reduced maintenance costs
- High strength pins provide higher strength and increased wear resistance
- Engineered and tested in rigorous real-life conditions

Specifications

A. Maximum Dig Depth	76"
B. Maximum Reach	78"
C. Swing Angle	140°
Weight with 12 inch bucket	535 lbs
Bucket Dig Force	3800 lbs
Host Machine Requirements	
Lift Capacity	30 HP or 1200 lbs
Minimum Auxillary Hydraulics	6 GPM
Power Source	12 Volts

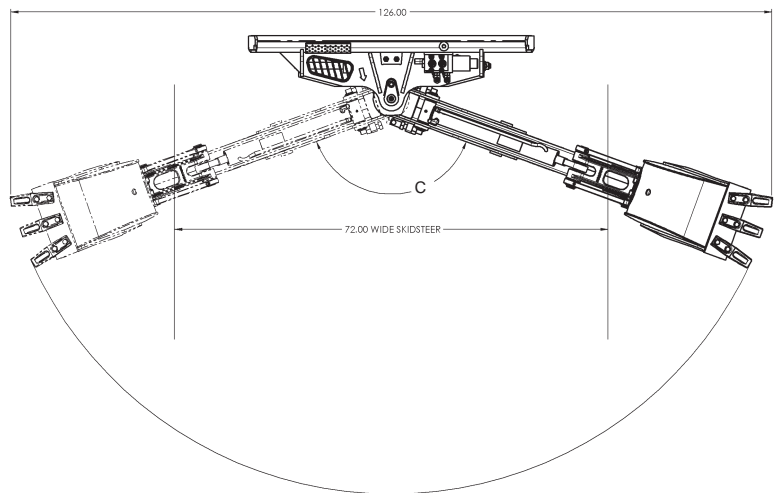
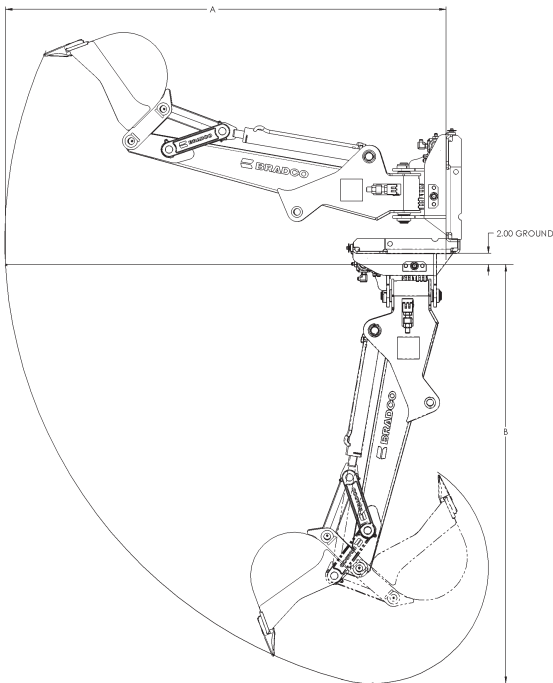

PH: (800) 922-2981
 FX: (563) 922-2700

PO Box 266
 Delhi, IA 52223
 United States of America

www.bradcoattachments.com

Swing Hoe 0807-1

