

# Buckets

For Compact Wheel Loaders, Telehandlers, Tractor Loader Backhoes with quick attach systems

## FEATURES:

- provides the most cost effective and efficient way to complete your job
- manufactured with high quality, ensuring a long and productive life
- 1 year warranty



PALADIN LIGHT CONSTRUCTION



# General Purpose & Light Material Buckets

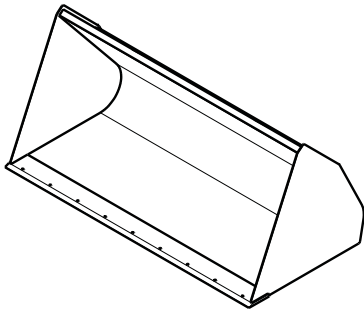

## FEATURES:

- Rolled shell for easy filling and clean up
- Full cross member torque tubes top and bottom for long term durability
- Abrasion resistant cutting edge with punched holes for optional bolt-on edge
- Skid plates under bucket shell for improved wear
- Optional bolt on cutting edges
- High visibility version on larger buckets allows for improved visibility through the bucket when empty
- Rugged design ideal for various digging and loading operations
- 1 year warranty

Specifications	Minimum	Maximum
A. Overall height	varies depending upon cubic capacity	
B. Overall depth	varies depending upon cubic capacity	
C. Overall width (96" standard)	48	102
Capacities	1/2 cu. yd.	4 cu. yd.
weight (approximate)	450 lbs	1727 lbs

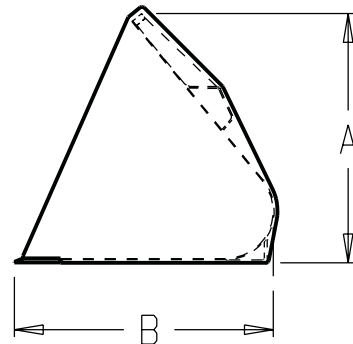

PH: (800) 922-2981  
 FX: (563) 922-2700

P.O. Box 266  
 Delhi, IA 52223-0266  
 United States of America

[www.paladinbrands.com](http://www.paladinbrands.com)

M - Buckets 0704-1



PALADIN LIGHT CONSTRUCTION